

REVISIONS			
REV	DESCRIPTION	DATE	APPROVED
--	--	--	--

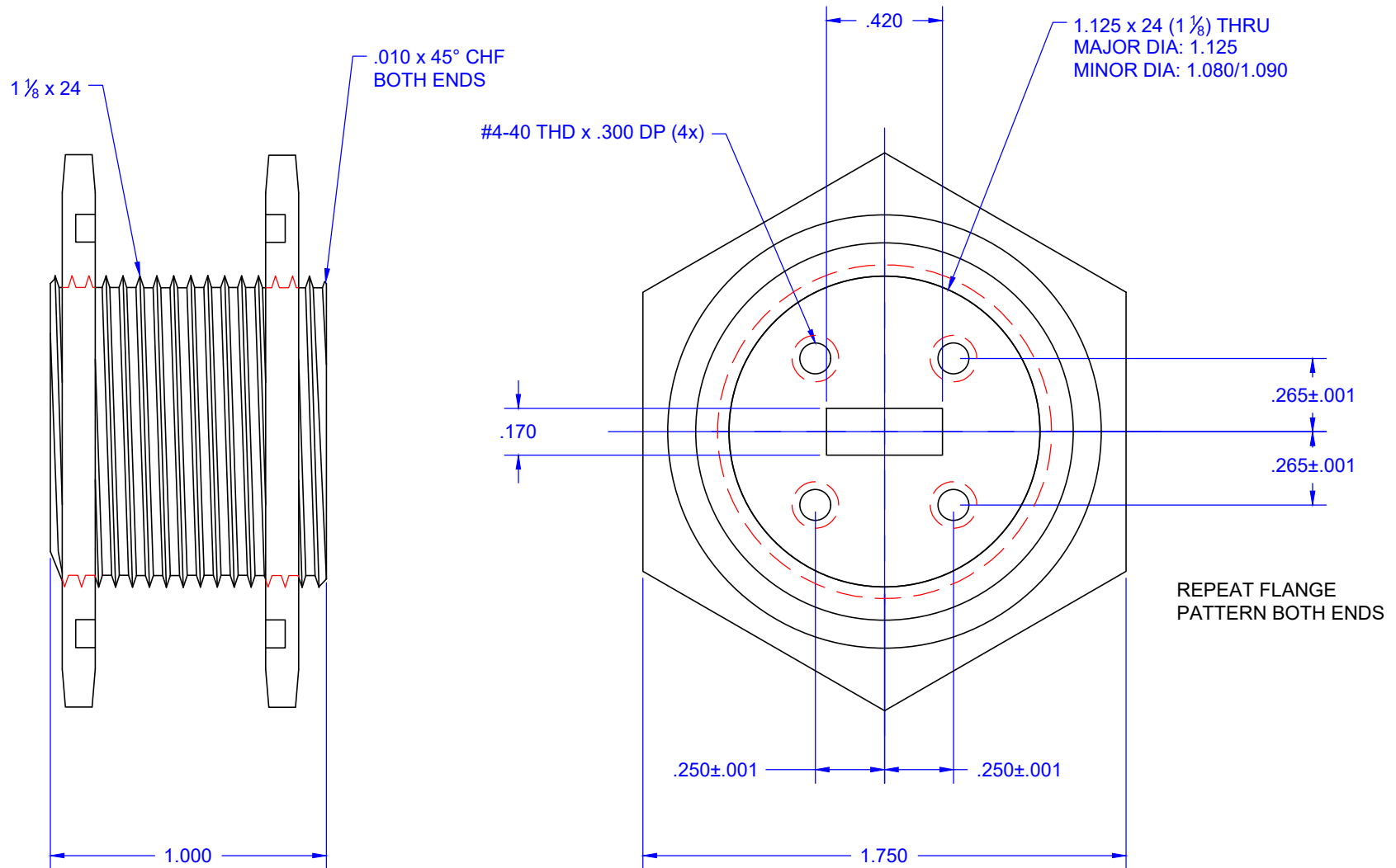

--	--	MATERIAL: 1/2 HARD BRASS		--
QTY	PART NUMBER	DESCRIPTION		ITEM
UNLESS OTHERWISE SPECIFIED ALL SURFACES $\sqrt{32}$		 THIRD ANGLE PROJECTION		Mi-Wave Millimeter Products Inc. 712K SQUARE FLANGE OUTLINE
DIMENSIONS ARE IN INCHES TOLERANCES ARE: DECIMALS: .1234 +/- .0005 .123 +/- .005 .12 +/- .01 ANGLES: +/- .5 DEGREES				
ALL THREADS TO BE 2A OR 2B		SHEET NO.	OF	SIZE
REF DWG #: 10948		1	1	DWG NO
				A 26031